

# **Ultrasonic Anemometer with Light & UV, Thermo-hygrometer Sensors Model: WS80**

## **Contents**

1. Introduction .....	2
2. Unpacking .....	2
3. Overview .....	5
4. Setup Guide .....	6
4.1 Install batteries in sensor package .....	6
4.2 Mount ultrasonic anemometer assembly .....	7
5. Wi-Fi Configure with gateway .....	15
5.1 Pair with gateway or display console .....	15
5.2 Wi-Fi Connection .....	16
6. View Online Data on WS View Plus or Ecowitt App	16
7. Specification .....	17
7.1 Wireless Specifications: .....	17
7.2 Measurement Specification .....	18
7.3 Power consumption .....	19
8. Warranty Information .....	19
9. URL of This Manual .....	20

# 1. Introduction

Thanks for your purchasing this WS80 6-in-1 Ultrasonic Sensor Package. This device measures wind speed, wind direction, temperature, humidity, UV Index and solar radiation. The Ultrasonic Sensor Package is solar powered and sends data to the receiver via a low-power radio. The data can be streamed by GW1100 Wi-Fi Gateway (sold separately) or HP2551/HP2553 console display (sold separately); and can be viewed on our WS View Plus or Ecowitt App application after the Wi-Fi configuration done. To ensure the best product performance, please read this manual and retain it for future reference.

## 2. Unpacking

Open your weather station box and inspect that the contents are intact (nothing broken) and complete (nothing missing). Inside you should find the following:

QTY	Item Description
1	Solar powered ultrasonic anemometer with Light and UV, air temperature/humidity sensor integrated( optional heater for climate with snow/ice conditions available)
1	U-Bolts set for mounting on a pole (2pcs/set)
1	Threaded nuts for U-Bolts set (M6 size) (4pcs/set)
1	Mounting arm for ultrasonic anemometer
1	Mounting bracelet for ultrasonic anemometer
1	User manual (this manual)
1	3M extension cord

### Table: Package content

If any component is missing from the package, or broken, please contact our Customer Service department to resolve the issue.

**Note:** Batteries for the ultrasonic anemometer are not included. You will need 2 AA size Lithium battery for the ultrasonic anemometer, which is primarily for startup and backup

purpose. After setup and during normal operation, the unit is getting its power from solar cell.

**Note:** There's a built-in heat plate in the 6-in-1 sensor package body, if the lowest temperature at your place is below  $-3^{\circ}\text{C}$ , or  $26.6^{\circ}\text{F}$ , and the weather is mostly snowy or rainy, then you may need to activate the heater by supplying an external 12V/1A power to the sensor heating element for melting accumulated snow or ice, which can influence wind measurement accuracy significantly. Please contact us at [support@ecowitt.com](mailto:support@ecowitt.com) for the extension cord information if needed.

There's a built-in thermostat inside the anemometer sensor to control the power supply for the heat plate, which will automatically turn on below  $0^{\circ}\text{C}$  ( $30^{\circ}\text{F}$ ) and automatically turn off above  $10^{\circ}\text{C}$  ( $50^{\circ}\text{F}$ ).

### 3. Overview

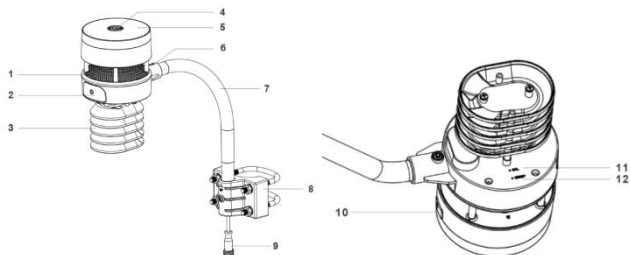

**Figure 1: Sensor package assembly components**

1. Surface tension conditioner layer ( patent pending)	7. Mounting arm
2. Battery compartment	8. Mounting bracelet and U-bolt set
3. Temperature & humidity sensor	9. Power cord for built-in heater
4. Light & UV sensor, LED indicator	10. USB port (factory use only)
5. Solar Panel	11. Calibration button (factory use only)
6. NORTH alignment indicator	12. Reset button

**Table: Sensor package assembly component list**

## 4. Setup Guide

### 4.1 Install batteries in sensor package

Open the battery compartment with a screwdriver and insert 2 AA batteries in the battery compartment, and press “Reset” button, the LED indicator on the back of the sensor package (item 4) will turn on for 3 seconds and then flash once every 4.8 seconds indicating sensor data transmission. If you did not pay attention, you may have missed the initial indication. You can always press the reset button to start over. Make sure you see the flash once every 4.8 seconds.

If sensor has been put outside for some time, and solar panel has charged up the internal accumulator fully or partially, if you install the 2 AA backup battery, the system might not start up properly. So you can always make a system reset by press the “Reset” button.

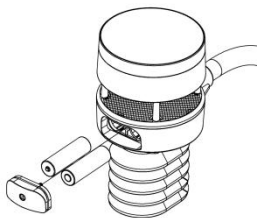

**Figure 2: Battery installation diagram**

**Note:** Please make sure the battery is inserted correctly for its polarity as the system needs its initial power from this backup battery to start up the system before solar panel charges up the accumulator and supply system power afterwards. when in high altitude area, during wintertime, sunshine time is short, thus system needs to be powered from this backup battery, we recommend Lithium batteries to be used for cold weather climates. Please avoid alkaline batteries, especially when internal heater is to be activated during cold and wet weather conditions as when heater activated, the trapped heat inside will warm up internally, and alkaline batteries are extremely susceptible to leakage when temperature is over certain limits.

## **4.2 Mount ultrasonic anemometer assembly**

### **4.2.1 Before you mount**

Before installing your outdoor sensor in the permanent location, we recommend operating the device for one week in a temporary location with easy access. This will allow you to check out all of the functions, ensure proper operation and familiarize you with the device performance.

## 4.2.2 Mounting

- You can attach a pole(not included) to a permanent structure and then attach the sensor package to it (see [Figure 3-8](#)).
  - The U-Bolts will accommodate a pole diameter of 1.25-2 inches (pole not included).
1. Install the base on a pole (1.25inch~2inch) as [Figure 3](#).

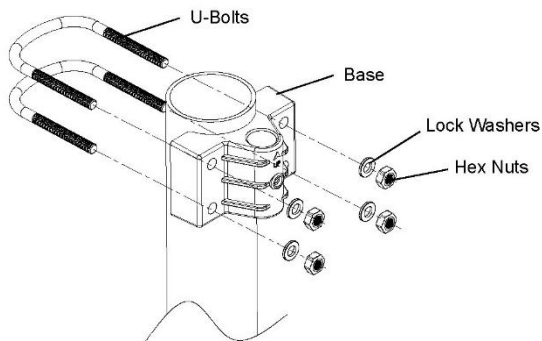

**Figure 3: Sensor package mounting diagram 6-1**

2. Pass the connector cord through the arm tube as [Figure 4](#):



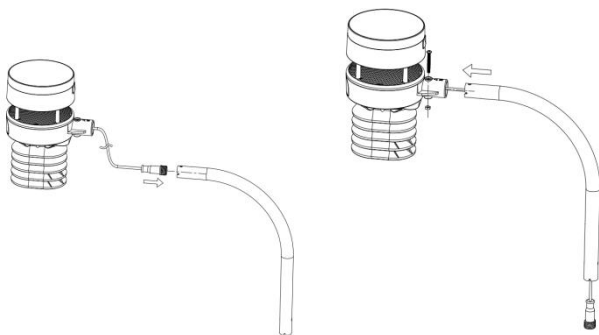

**Figure 4: Sensor package mounting diagram 6-2**

3. Attaching the arm tube to the Ultrasonic Sensor as Figure 5.

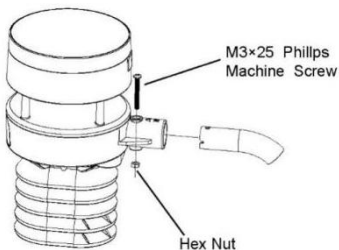

**Figure 5: Sensor package mounting diagram 6-3**

4. Install the base with U-bolts and threaded nuts to a pole (not included) as Figure 6 shows:

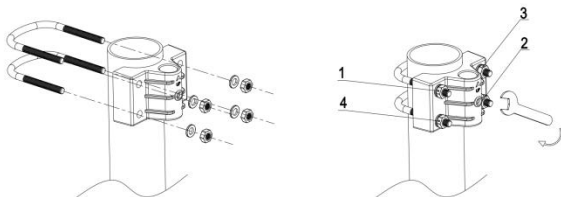

**Install each M6 nut in the order 1,2,3 then 4.**

Do not tighten with an impact driver.

Hand tighten, then a half turn/180°

No more. If your mounting pole

is a soft material (wood, pvc, etc.)

you may need to retighten the

M6 nuts when you perform your

maintenance every 3 months.

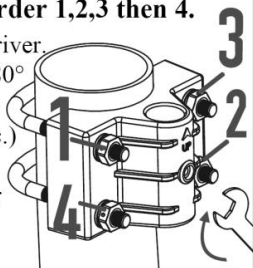

**Figure 6: Sensor package mounting diagram 6-4**

5. Insert the arm tube into the base as Figure 7. Be sure to line up the small hole in the arm with the holes in the base. Insert the machine screw through the holes in the base and arm. ( if you don't need to

power up the heater, you should keep the power cord terminal inside the mounting arm and this can make the installation looks neat and tidy. You may take it out when needed.)

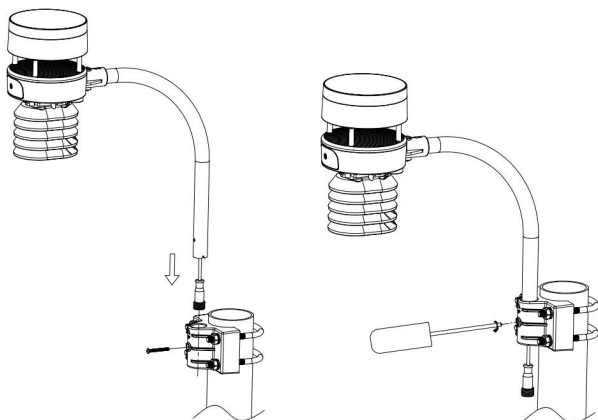

**Figure 7: Sensor package mounting diagram 6-5**

Make sure the mounting pole is vertical, or very close to it. Use a level as needed.

6. During wintertime, to prevent ice formed on the reflection surface, The package including a 3M extension cord ,Please connect the cord to the connector that client want as Fingure 8 show

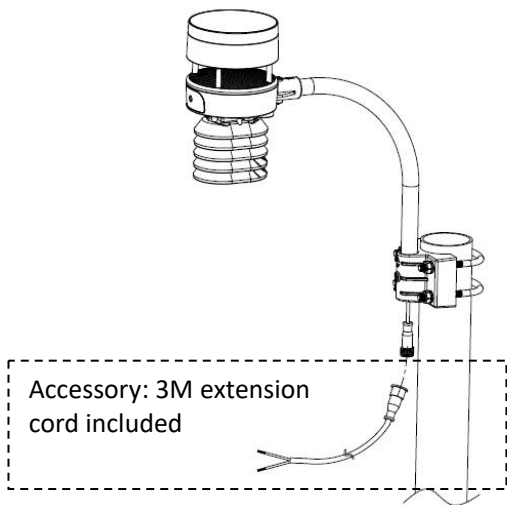

**Figure 8: Sensor package mounting diagram 6-6**

7. If optional extension cord is added, connect extension cord and then connector AC adaptor as Figure 9 show:

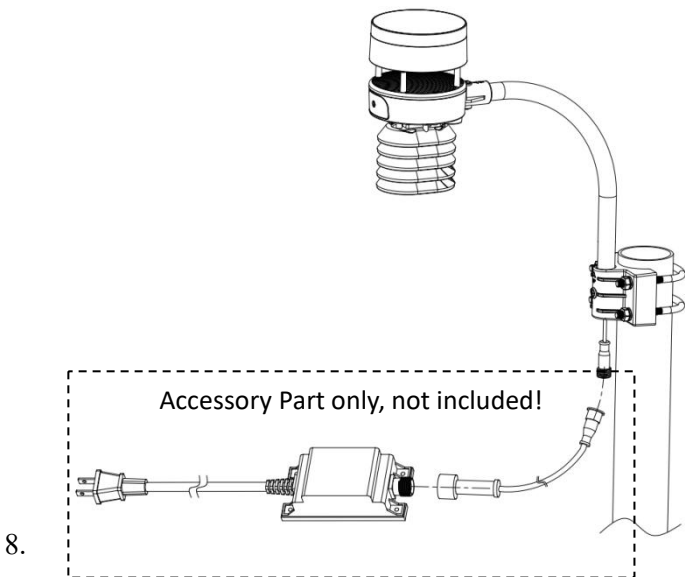

**Figure 9: Sensor package mounting diagram 6-7**

Finally, place the sensor package on top of the prepared mounting pipe. The U-Bolts should be loose enough to allow this but loosen the nuts as necessary. Once placed, hand tighten all four nuts, taking care to do so evenly. Do not use a wrench yet!

Now you will need to align the whole package in the proper direction by rotating it on top of the mounting pipe as needed. Locate the arrow labeled “NORTH” that you will find on top of the connector tube of the sensor package (item 6). You must rotate the whole sensor package until this arrow points due north. To achieve proper alignment, it is helpful to use a compass (many cell phones have a compass application). Once rotated in the correct orientation, lightly tighten the bolts a little more (use a wrench) to prevent further rotation.

**Note:** In Southern hemisphere, it is not necessary to change the orientation to SOUTH as its solar panel is a rounded type and it is orientation free for its charging capability.

Make sure the mounting tube for the sensor package is installed vertically (use a level at 90-degree offsets around the tube). Adjust the mounting pipe as necessary. Next also make sure the mounting of the anemometer body on the pipe is level. If it is not, wind direction and speed readings may not operate correctly or accurately. Adjust the mounting assembly as necessary.

Make sure you check, and correct if necessary, the north orientation again, as the final installation step, and now tighten the bolts with a wrench. Do not over

tighten, but make sure strong wind and/or rain cannot move the sensor package.

### **4.2.3 Reset Button and Transmitter LED**

In the event the sensor package is not transmitting, reset the sensor.

Using a bent-open paperclip, press and hold the RESET BUTTON (item 12) to affect a reset: the LED turns on while the RESET button is depressed, and you can now let go. The LED should then resume as normal, flashing approximately once every 4.8 seconds.

## **5. Wi-Fi Configure with gateway**

If you want to view the Ultrasonic Sensor data on your mobile application, you need to pair this device with our GW1100 Wi-Fi Gateway or HP2551/HP2553 display console (sold separately).

### **5.1 Pair with gateway or display console**

Please follow the tips to pair your sensor(s) with the Wi-Fi Gateway or HP2550/HP2551 display console:

- 1) Power on the gateway first (with USB connection)

or HP2551/HP2553 display console (with adaptor connection)

2) Power on the Ultrasonic sensor.

3) The RF status indicator of the gateway will light on steady, and light off once when it receives the data from the optional sensor(s) once.

4) If work normally, you can forward to the Wi-Fi connection operation.

## **5.2 Wi-Fi Connection**

For this part, please refer to the manual of the GW1100 Wi-Fi gateway or HP2551/HP2553 Wi-Fi Weather Station.

Any question, please contact the customer service.

## **6. View Online Data on WS View Plus or Ecowitt App**

When the Wi-Fi configuration is done, you can view the live data of your ultrasonic sensor on the WS View Plus or Ecowitt App application(only for the GW1100 gateway).



Back	Live Data GW1000B-WF71A0		More
Indoor Temperature	27.6 °C	Indoor Humidity	54 %
Outdoor Temperature	27.9 °C	Outdoor Humidity	54 %
Absolute Pressure	1017.3 hPa	Relative Pressure	1019.3 hPa
Solar Radiation	0.00 w/m <sup>2</sup>	UV-Index	0
Wind Speed	0.00 km/h	Wind Direction	
Wind Gust	0.00 km/h		
Firmware Version GW1000B_V1.5.1			

## 7. Specification

### 7.1 Wireless Specifications:

Frequency: 433/868/915/920MHz depending on location (North American:915MHz; Europe:868MHz; Other areas:433/920MHz)

Transmission distance in open field:  
150m(492 ft) for RF Frequency :915 Mhz /868 Mhz  
/920Mhz/433MHz

Sensor reporting interval: 4.8 seconds

**Note:**

- When the maximum wind speed of the last 4s is  $\geq 5\text{m/s}$ , the wind speed is detected by 1s; when the maximum wind speed of the last 4s is  $\geq 3\text{m/s}$  and less than  $5\text{m/s}$ , the wind speed is detected by 2s; when the maximum wind speed of the last 4s is  $< 3\text{m/s}$ , the wind speed is detected by 4s.
- The wind speed reading will be a real-time value (The latest sampling data will be reporting to the receiver).
- The wind gust reading will be the max wind speed in the past 28s.
- When the wind speed is lower than  $5\text{m/s}$ , the dispersion of wind direction will increase.

## 7.2 Measurement Specification

Measurement	Range	Accuracy	Resolution
Wind speed	0~40m/s	$<10\text{m/s}$ , $\pm 0.5\text{m/s}$ $\geq 10\text{m/s}$ , $\pm 5\%$	0.1M/S
Wind direction	0~359°	$<10\text{m/s}$ , TBA $\geq 10\text{m/s}$ , $\pm 15^\circ$	1°

Temperature	-40~60℃	±1℃	0.1℃
Humidity	1~99%	±5%	1%
Light	0~300Klux	±15%	10Lux
UVI	1~15	±2	1

## 7.3 Power consumption

Power	Specification
Anemometer sensor	Solar panel (built-in): 6.5V/4mA
Anemometer sensor (backup)	2 x AA 1.5V Lithium battery (not included)

Note: The primary power source for the sensor is the solar panel. When available solar power (light over recent period) is insufficient, the batteries will be used.

## 8. Warranty Information

**We disclaim any responsibility for any technical error or printing error, or the consequences thereof.**

**All trademarks and patents are recognized.**

We provide a 1-year limited warranty on this product against manufacturing defects, or defects in materials and workmanship.

This limited warranty begins on the original date of purchase, is valid only on products purchased, and only to the original purchaser of this product. To receive warranty service, the purchaser must contact us for problem determination and service procedures.

This limited warranty covers only actual defects within the product itself and does not cover the cost of installation or removal from a fixed installation, normal set-up or adjustments, or claims based on misrepresentation by the seller, or performance variations resulting from installation-related circumstances.

## **9. URL of This Manual**

**<https://www.ecowitt.com/support/download/34>**

- Please view this URL and you can download the electronic archives of this manual.

- Bitte sehen Sie sich diese URL an und Sie können das elektronische Archiv dieses Handbuchs herunterladen.
- Visualizza questo URL e puoi scaricare gli archivi elettronici di questo manuale.
- Consulte esta URL y podrá descargar los archivos electrónicos de este manual.
- Veuillez consulter cette URL et vous pourrez télécharger les archives électroniques de ce manuel.
- Por favor, veja este URL e você pode baixar os arquivos eletrônicos deste manual.
- Proszę zobaczyć ten adres URL, aby pobrać elektroniczne archiwa tego podręcznika.